

EN



# SYNOFOG

User Documentation



[www.veugentech.com](http://www.veugentech.com)

# Preface

## About this manual

This document is intended for the Synofog (all types). In this manual, the Synofog will be referred to as the machine.

Make sure you have fully read and understood this manual before you start using the machine. Store the manual for future use. We recommend storing a manual in the archive of your technical department, in case the documentation gets lost. An extra copy can be requested from your supplier.

This manual was originally written in the Dutch language. All other languages are translations from the Dutch document.

## Copyright

© Copyright: Veugen Technology B.V., Nederweert, 2024

Nothing from this documentation may be reproduced in whatever form without the permission of Veugen Technology B.V. This is with the exception of parts intended for reproduction for use of this documentation, such as abridged instructions and indications on the product.

# Contents

<b>1. Introduction</b>	<b>4</b>	<b>6. Use</b>	<b>19</b>
1.1. Target group	4	6.1. Starting the fogging process	19
1.2. Symbols in this manual	5	6.2. During the fogging process	19
1.3. Declaration of conformity	5	6.3. Switching off the machine	20
<b>2. Description of the machine</b>	<b>6</b>	<b>7. Maintenance</b>	<b>21</b>
2.1. Intended and unintended use	6	7.1. Maintenance after each use	21
2.2. Description	6	7.2. Regular maintenance	24
2.3. Delivery	6	7.3. Repairs	24
2.4. Main components	7	<b>8. Troubleshooting</b>	<b>25</b>
2.5. Display	9	8.1. Alarm via the screen	26
2.6. Data plate	9	8.2. Alarm via LED indicators	27
2.7. Specifications	10	<b>9. Disposal</b>	<b>28</b>
<b>3. Safety instructions</b>	<b>11</b>	<b>10. Contact</b>	<b>28</b>
3.1. Precautionary measures	11	<b>11. Replacement parts</b>	<b>29</b>
3.2. Symbols and marks on the product	11	<b>12. Accessories</b>	<b>35</b>
3.3. Personal protective equipment	11	12.1. Extension pieces	35
3.4. Safety instructions	11	12.2. Wi-Fi	36
<b>4. Storage and transport</b>	<b>13</b>	12.3. 4G	37
4.1. Storage	13	12.4. Other accessories	37
4.2. Transport	13	<b>13. Guarantee</b>	<b>39</b>
<b>5. Installation</b>	<b>14</b>	<b>14. EC declaration of conformity</b>	<b>40</b>
5.1. Installation instructions	14		
5.2. Language and time settings	17		
5.3. Changing the blower frequency (only Synofog HR)	18		

# 1. Introduction

## 1.1. Target group

---

This manual is intended for the following target groups:

- Operator
- Service personnel
- Safety officer

Work performed by the supplier or manufacturer has not been included in this document.

### 1.1.1. Operator

The operator is the daily user of the machine. The operator is an adult person who has been instructed in the use of the machine.

All chapters up to and including chapter Maintenance after each use (57.1) are relevant to the operator.

### 1.1.2. Service personnel

Service personnel are personnel that are allowed to perform maintenance at the machine. In addition to the requirements that operators should comply with, service personnel must meet the following requirements:

- Training or knowledge at Secondary Technical Education level in the field of electromechanics.
- Experience of servicing activities.

All chapters are relevant to service personnel.





### 1.1.3. Safety officer

The safety officer is the person who is responsible for the working conditions at the company. He or she should be familiar with the chapters Safety instructions (53) and Specifications (52.7). If no-one has been assigned for this function, the employer shall be the safety officer.

## 1.2. Symbols in this manual

---

The following symbols are used in this manual:

	<b>Tip!</b> This symbol indicates information that can be useful to the reader.
	<b>Caution!</b> This symbol warns about possible damage to the product.
	<b>Warning!</b> This symbol warns about possible personal injuries.
	<b>Danger to life!</b> This symbol warns about a situation that can be life threatening.
	<b>Fire hazard!</b> This symbol warns about a risk of fire.

## 1.3. Declaration of conformity

---

The Synofog was manufactured in accordance with the following standards and directives:

- 2006/42/EC
- 2014/30/EU EMC Directive
- 2009/127/EC
- EN ISO 13732

Consult §14 for the complete declaration of conformity.

## 2. Description of the machine

### 2.1. Intended and unintended use

---

The machine is intended for fogging germ inhibitors, disinfectors and crop protection agents, etc., in an enclosed space.

The machine is only intended for fogging permitted liquids with a Tmax set to 50 °C below the self-ignition temperature of the liquid concerned.

The machine is not intended for fogging in the outdoor air with liquids that are not intended for such use. This could have very negative effects on the health of the operator and on the environment.

### 2.2. Description

---

The Synofog is an electrothermal fogging appliance. A liquid is converted into a fine fog in the fogging pipe. The machine has a blower that is used to generate an air stream. This air stream is heated and guided through the fogging pipe. There, the liquid is mixed with the hot air and distributed as fine fog.

### 2.3. Delivery

---

The delivery consists of the following parts:

<b>Synofog 1H (1HR)</b>	<b>Synofog 2H (2HR)</b>	<b>Part</b>
1×	1×	Synofog
25×	25×	Air filter
1×	1×	Card holder
1×	1×	Suction hose red
1×	1×	Suction hose black
1×	1×	Back-up heat seal
1×	1×	Manual

## 2.4. Main components

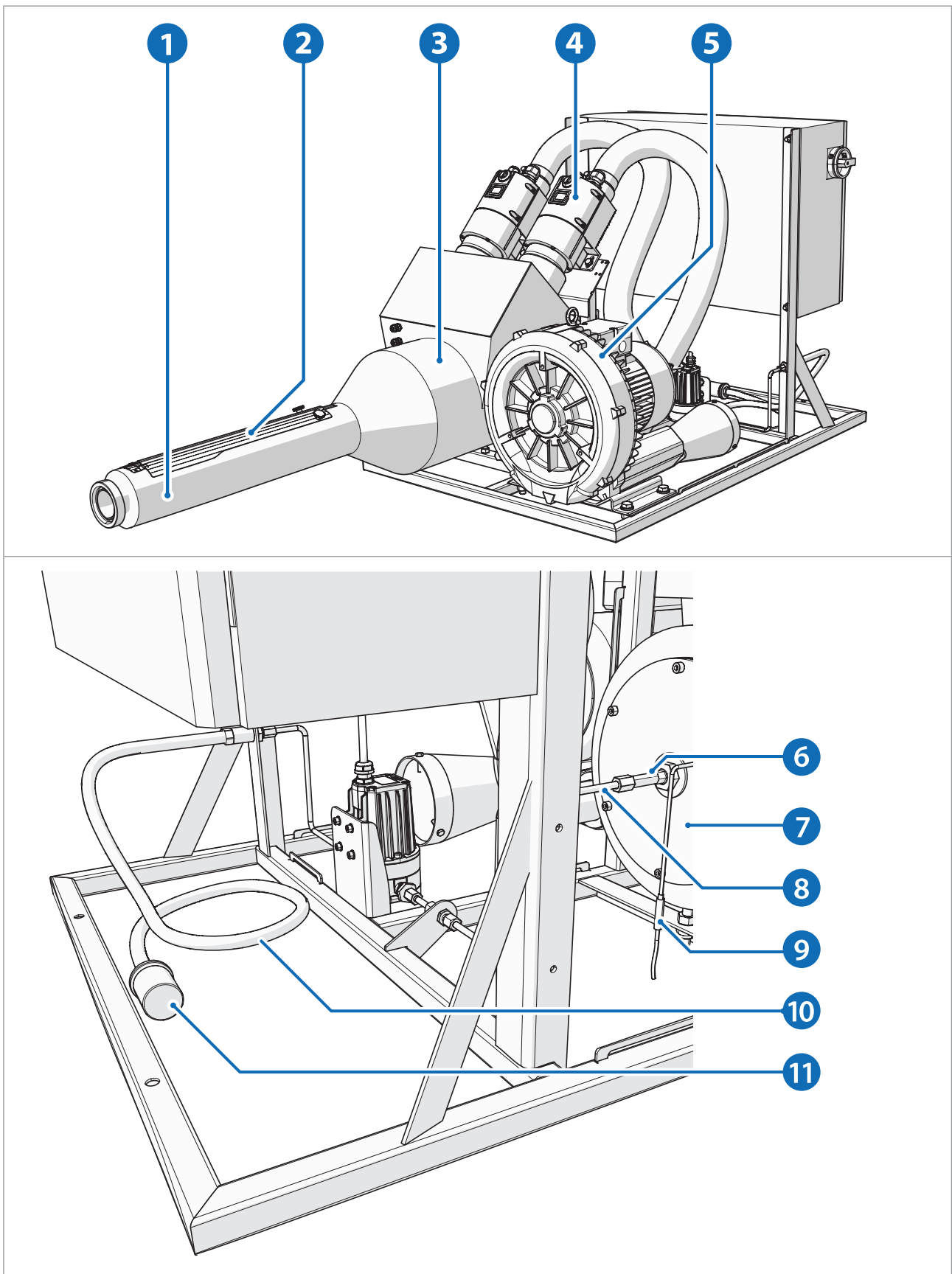

Figure 1 Main components

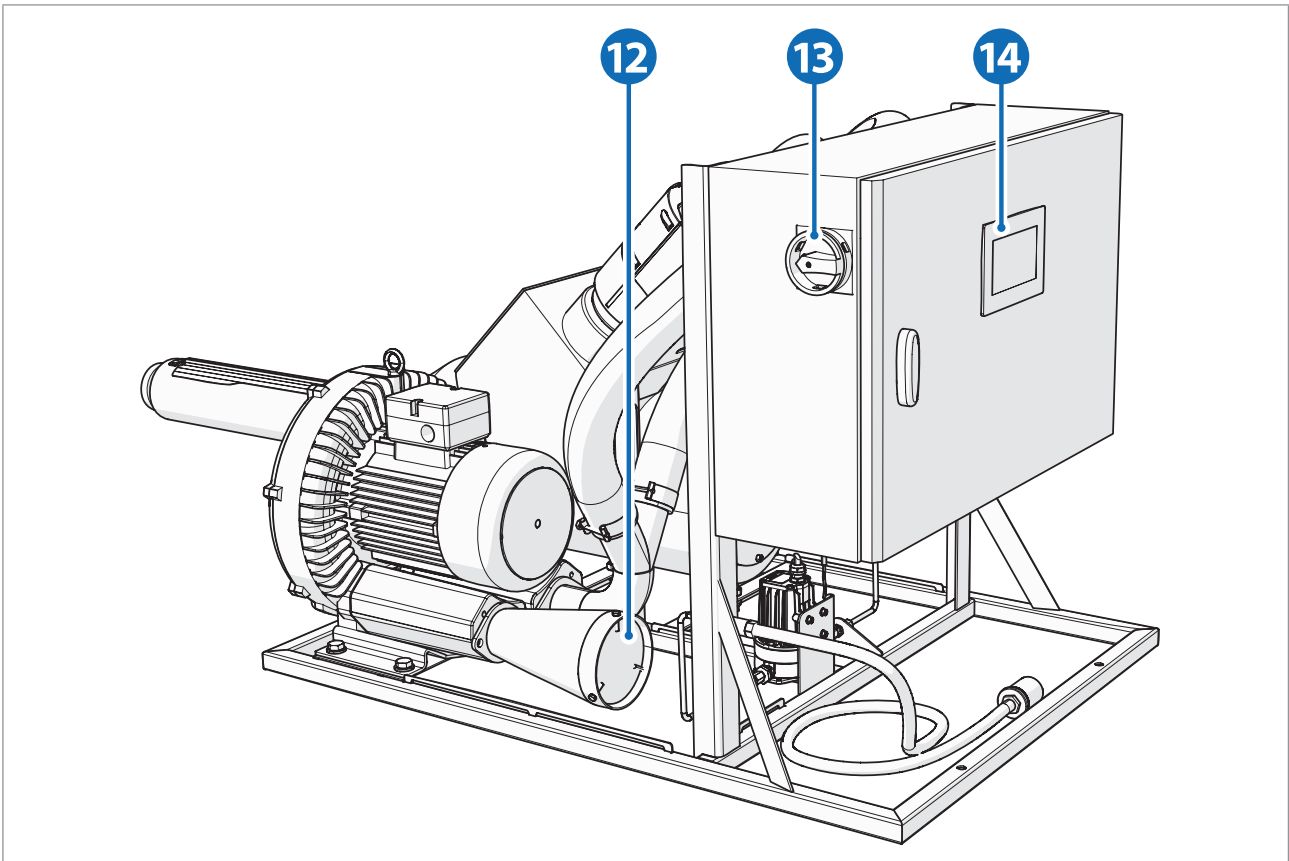

Figure 1 Main components

1. Fogging pipe
2. Fogging pipe sensor (Fog Temp)
3. Fogging chamber
4. Heater
5. Fan
6. Spray nozzle
7. Back plate with heat seal
8. Liquid pipe
9. Fogging chamber sensor (Max Temp)
10. Suction hose
11. Liquid filter
12. Air filter holder
13. Main switch
14. Display



## 2.5. Display



### Caution!

The display may look different, due to a difference in software versions.

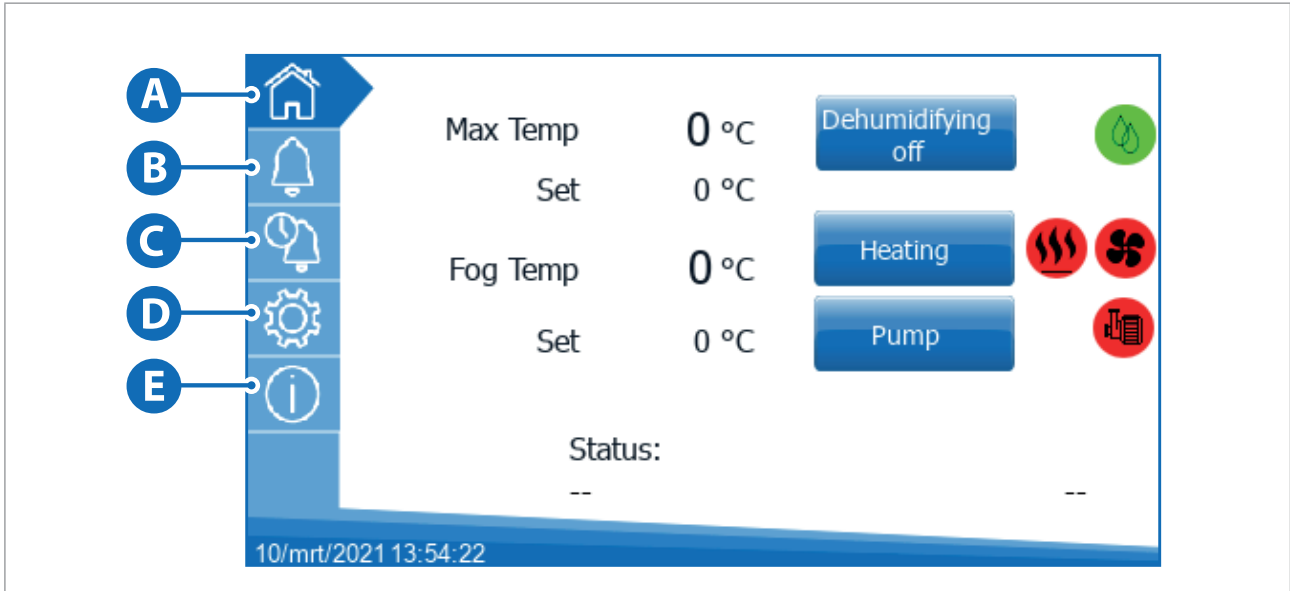

Figure 2 Display

- A. Start screen
- B. Active alarms
- C. Alarm history
- D. Technical data
- E. Information

## 2.6. Data plate

The data plate has been attached on the left side of the switch box.

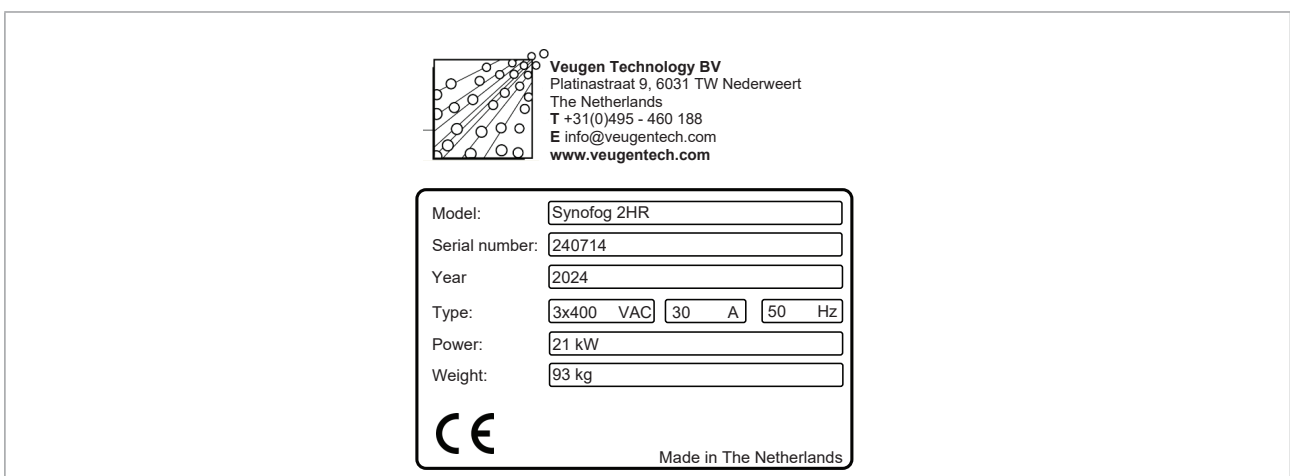

Figure 3 Data plate

## 2.7. Specifications

---

	<b>Synofog 1H (1HR)</b>	<b>Synofog 2H (2HR)</b>
Weight	82 kg	93 kg
Weight lift table	97 kg	97 kg
Material frame and liquid pipe	Stainless steel	Stainless steel
Capacity heating element	1 x 9 kW	2 x 9 kW
Total capacity	12 kW	21 kW
Noise emission	70 dB	70 dB
Capacity*	0 - 17 l/h	0 - 32 l/h
Voltage	400 VAC 17 A	400 VAC 30 A

\*The capacity depends on the following factors:

- Supply voltage
- Outdoor temperature
- Air humidity

# 3. Safety instructions

## 3.1. Precautionary measures

---

### 3.1.1. Emergency stop

In case of an emergency, the main switch also serves as an emergency stop. If an emergency occurs, you can fully switch off the machine by turning the main switch to 0 .



**Fire hazard!**

After use of the emergency stop, remove the fogging pipe from the hole and place the machine in a free space. It is possible that fire occurs in the fogging pipe.



**Caution!**

Do not use the emergency stop to switch off the machine in a normal situation.

## 3.2. Symbols and marks on the product

---

The following symbols and marks have been applied on the product:



**This symbol indicates that the surface can be hot during or immediately after use.**

Ensure that the symbols and marks remain legible at all times. Contact your supplier for replacement symbols.

## 3.3. Personal protective equipment

---

Wear the following protective equipment when using the machine:

- Full face mask with a filter that is suitable for the liquid used. For this, consult the Material Safety Data Sheet of the liquid
- Protective suit
- Gloves
- Rubber boots

## 3.4. Safety instructions

---

### 3.4.1. General



**Fire hazard!**

- Do not smoke near the machine.
- Make sure there is no open fire in the vicinity of the machine.

### 3.4.2. Transport and storage



#### Caution!

- Allow the machine to cool down fully before moving it. The heating elements could become damaged if the machine is moved.
- Properly fasten the machine for transport.

### 3.4.3. Installation



#### Fire hazard!

- Clean the machine in accordance with §7.1 after each use.
- Never use the machine for several liquids. Also not after thorough cleaning.



#### Caution!

Only use liquids that have been filtered with a 10 micron filter.

### 3.4.4. Use



#### Danger to life!

- Do not allow the machine to run without supervision. The operator must always be able to switch off the machine by switching off the main switch.
- Consult the Material Safety Data Sheets provided by the liquid supplier before using the liquid. The safety officer must be familiar with these documents.



#### Fire hazard!

- Do not fog liquids with a flash point below 70 °C.
- Never set the temperatures higher than 50 °C below the liquid's self-ignition temperature.
- Do not fog chlorinated liquids. Stainless steel could be affected by these liquids.
- Immediately switch off the power supply in case of a fire.
- In case of a power interruption, remove the fogging pipe from the hole and place the machine in a free space. After a power interruption, it is possible that fire occurs in the fogging pipe. Investigate and remedy the cause of the power interruption, before you start the machine again.
- In case of careless use, it is possible that fire occurs in the event of a power interruption.



#### Warning!

Do not close off the area around the fogging pipe during the treatment.

### 3.4.5. Maintenance



#### Fire hazard!

After use, clean the machine in accordance with §7.1.



#### Warning!

Before you start performing maintenance work:

- Check that the machine is off and that the plug has been disconnected.
- Allow the machine to cool down.

## 4. Storage and transport

### 4.1. Storage

---

Always store the machine in a covered area. The storage area must meet the following climate conditions:

Storage temperature	> 10 °C
Storage air humidity	< 60%

---

### 4.2. Transport

---



#### Caution!

- Allow the machine to cool down fully before moving it. The heating elements could become damaged if the machine is moved.
- Properly fasten the machine for transport.

During transport the machine should be covered. The transportation must meet the following climate conditions:

Storage temperature	> 10 °C
Storage air humidity	< 60%

---

# 5. Installation

## 5.1. Installation instructions

The machine is installed as follows:

1. Place the machine on a stable and flat surface, so that it cannot fall over or move.
2. If the machine is outdoors, protect it against weather influences.
3. If you use the lift table SF (§12.4), check the tension of the pneumatic tyres. The optimum tyre tension can be read on the side of the tyre.
4. Place a clean air filter in the air filter holder (see figure 4).

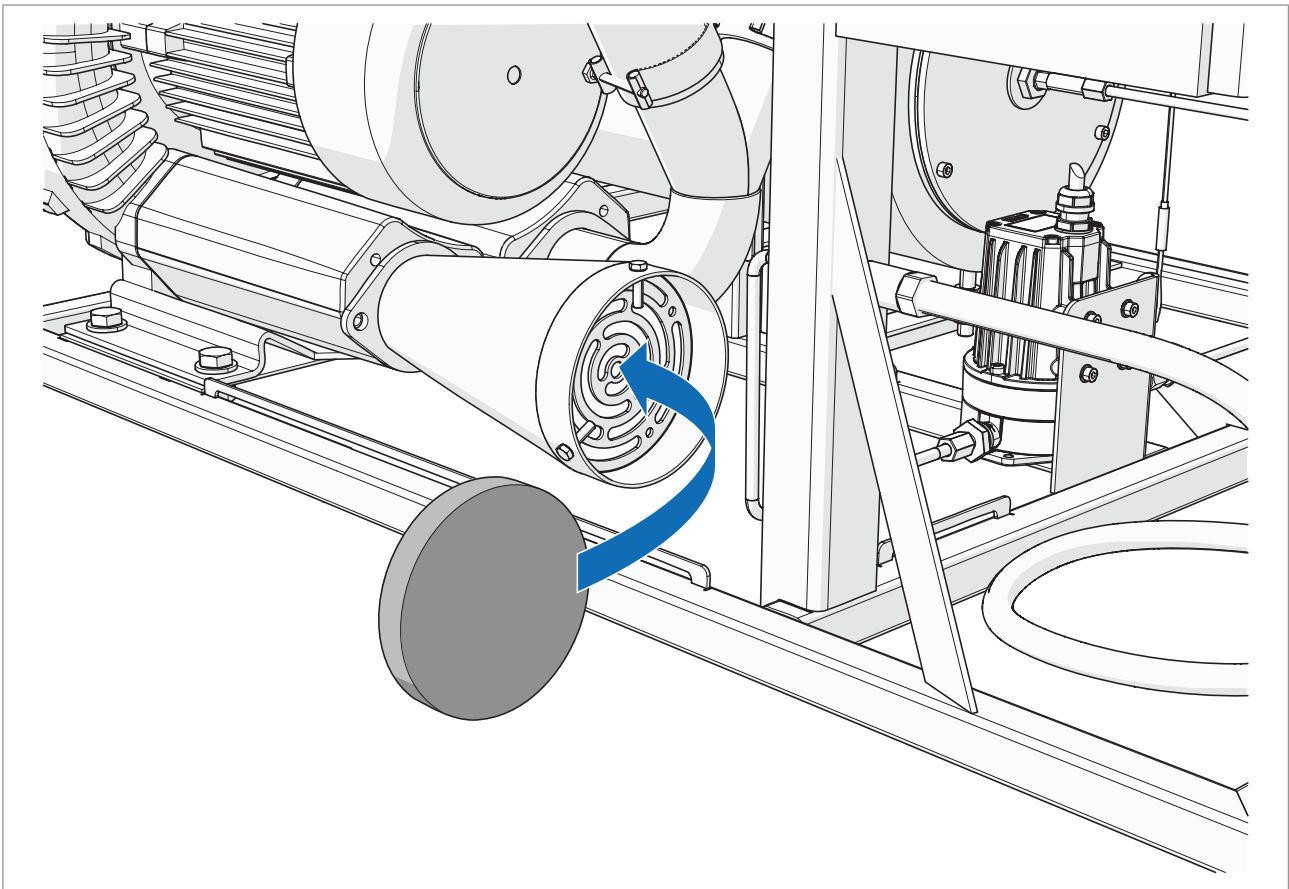

Figure 4 Placing a clean air filter



### **Danger to life!**

Consult the Material Safety Data Sheets provided by the liquid supplier before using the liquid. The safety officer must be familiar with these documents.



### **Caution!**

Only use liquids that have been filtered with a 10 micron filter.

5. Check that the correct suction hose has been mounted. If necessary, change the suction hose.
6. Place the suction hose in the liquid. The end of the suction hose must be fully submerged.
7. Insert the plug in a socket. Consult the table below for the power supply specifications.

	Synofog 1H (1HR)	Synofog 2H (2HR)
<b>Voltage</b>	360 - 430 V	360 - 430 V
<b>Power</b>	11 kW	21 kW
<b>Current</b>	17 A	30 A

8. Turn the main switch to 'I'.
9. Set Max Temp and Fog Temp (see 5.1.2).

### 5.1.1. Replace nozzle

To replace the nozzle, do as follows:

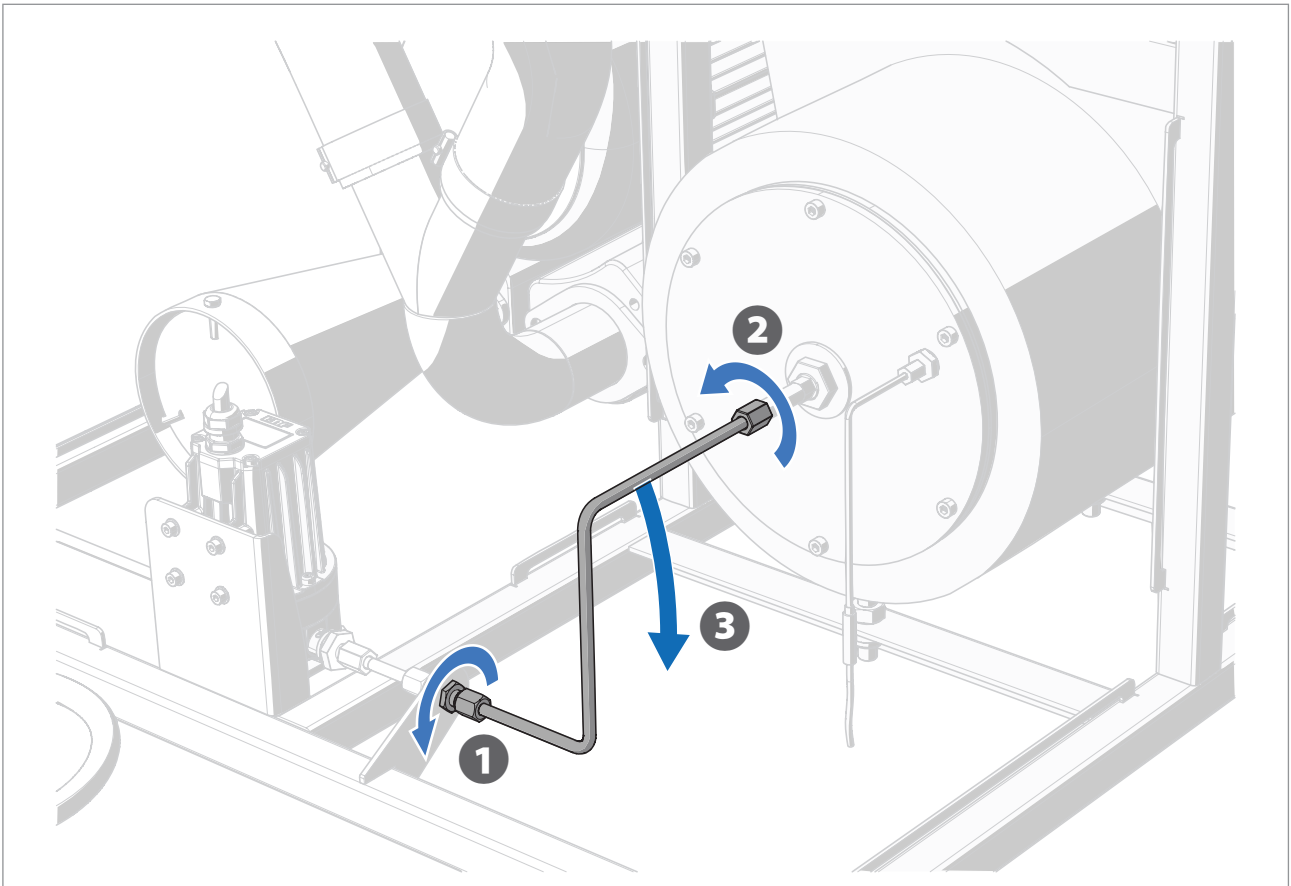

Figure 5 Disconnecting the liquid pipe

1. Disconnect the liquid pipe:
  - a. Slightly loosen the lower nut on the fluid line. ①
  - b. Fully loosen the nut on the fluid line at the back pleat with heat seal. ②
  - c. Turn the liquid pipe downwards. ③

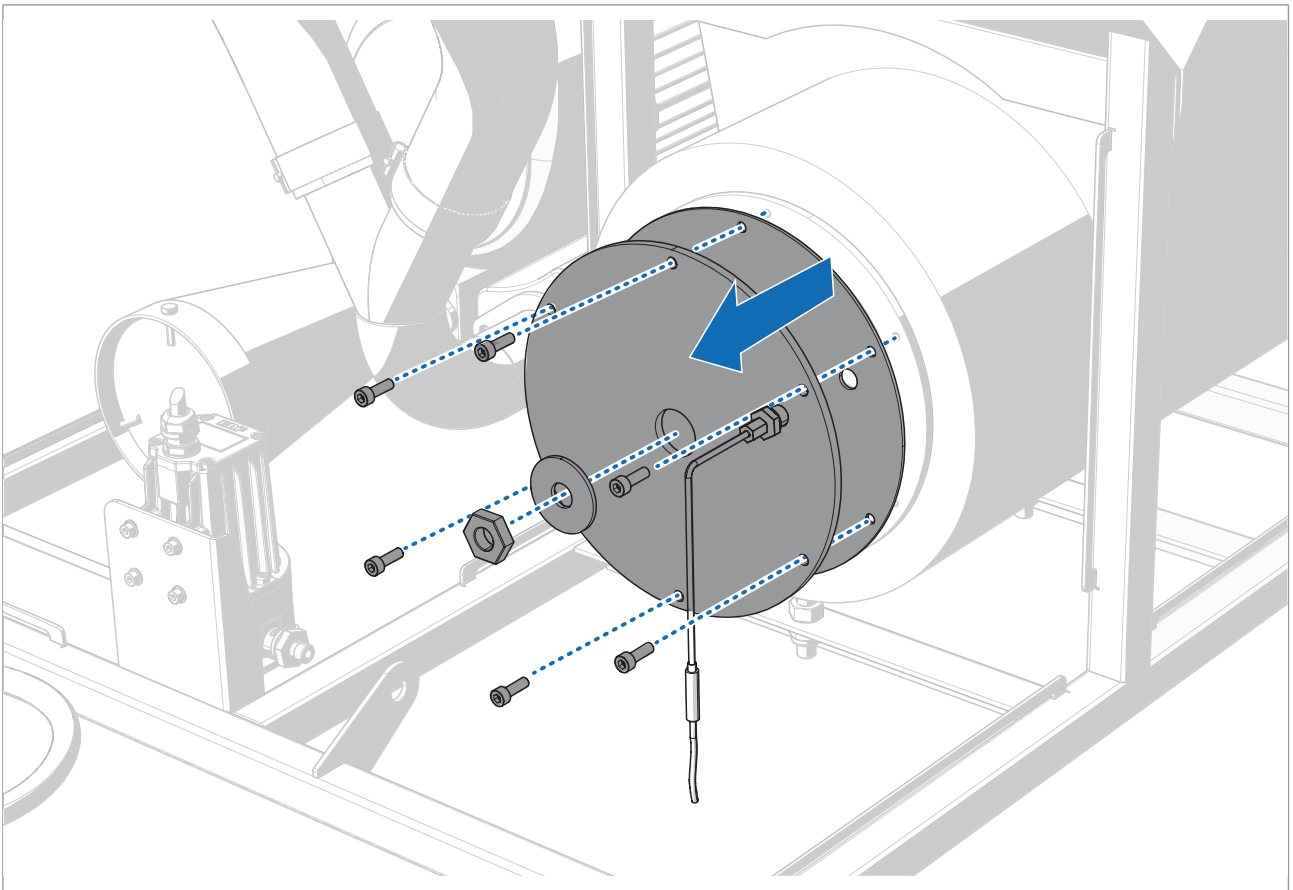

Figure 6 Remove back plate with heat gasket

2. Remove the back plate with heat seal from the machine.

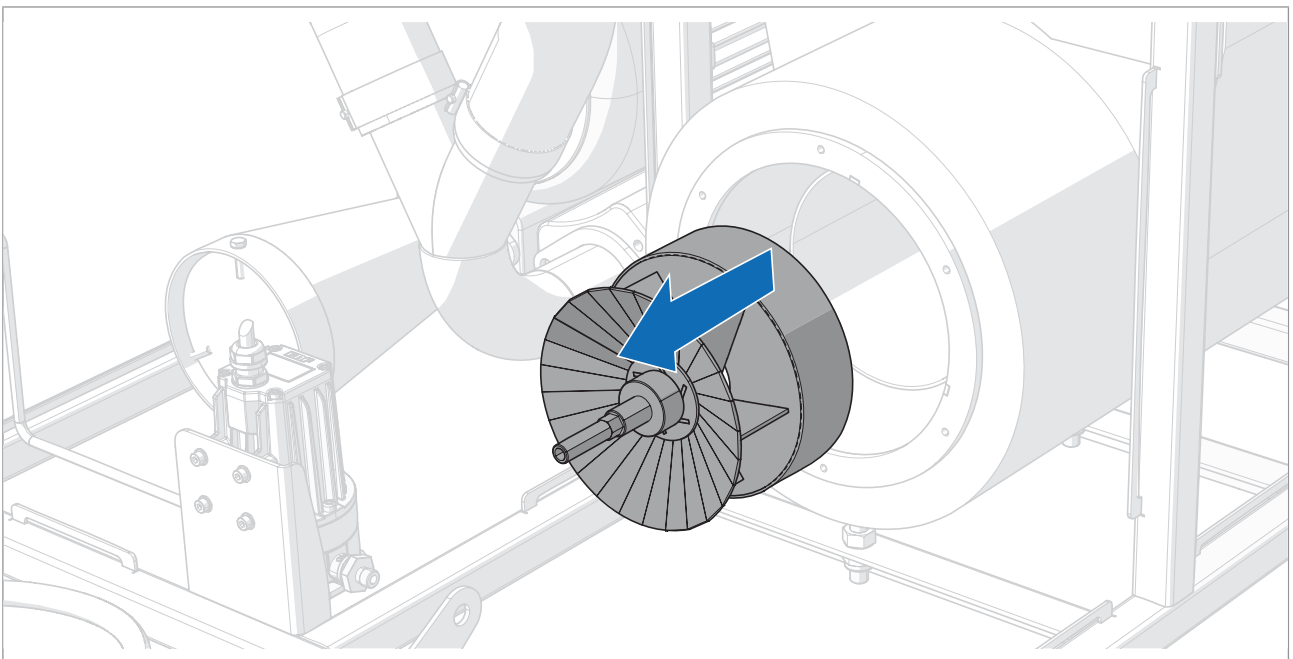

Figure 7 Changing the spray nozzle

3. Change the spray nozzle (see figure 7).
4. Place the back plate with heat seal back on the machine.
5. Connect the liquid pipe:
  - a. Turn the liquid pipe upwards.
  - b. Firmly tighten both nuts.



## 5.1.2. Setting the temperature

Two temperatures must be set prior to use.

- **Max Temp** is the maximum temperature in the fogging chamber. It is measured at the fogging chamber sensor. The heating element switches off when the measured temperature gets above the set Max Temp.
- **Fog Temp** is the temperature in the fogging pipe. It is measured at the fogging pipe sensor. The machine ensures that the fogging temperature remains as close as possible to the set Fog Temp by adjusting the pump speed.



### Caution!

The outdoor temperature may affect the viscosity of the liquid and the temperature of the air. This affects the fogging capacity, as a result of which fogging could take longer than expected.

Max Temp and Fog Temp are set as follows:

1. Determine the liquid's self-ignition temperature. Consult the Material Safety Data Sheet.



### Fire hazard!

Never set the temperatures higher than 50 °C below the liquid's self-ignition temperature.

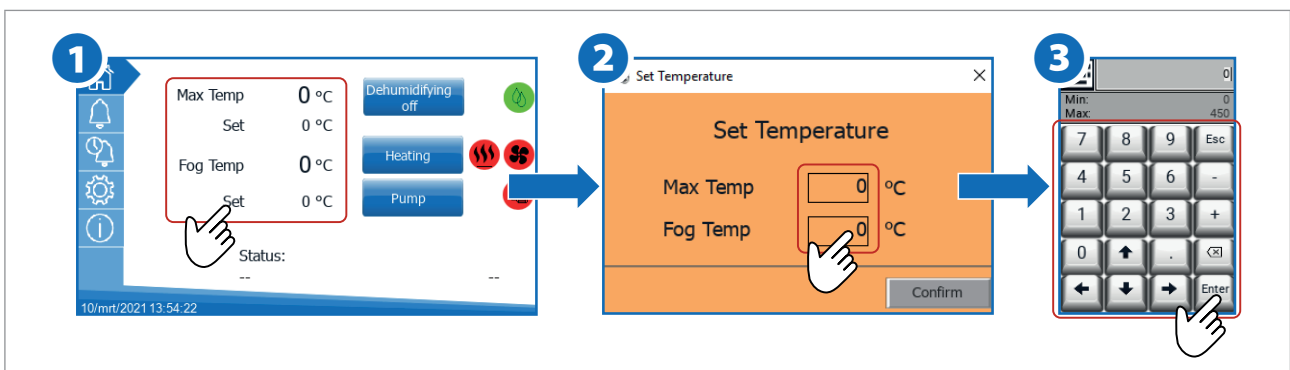

Figure 8 Setting the temperature

2. Press Set.
3. Press the value next to Max Temp.
4. Enter the required maximum temperature. The Max Temp is limited to 450 °C.



### Fire hazard!

Never set the temperatures higher than 50 °C below the liquid's self-ignition temperature. See the label of the fogging liquid for more information, or consult the supplier of the liquid.

5. Press Enter to confirm the temperature.
6. Press the value next to Fog Temp.
7. Press Enter to confirm the temperature.
8. Press Confirm to confirm the values.

## 5.2. Language and time settings

Under the information tab you can adjust the language and time. Here you can also read the current software version.

### 5.3. Changing the blower frequency (only Synofog HR)

In the case of the H versions of the Synofog, the temperature is controlled by means of the blower frequency. In the case of the HR versions of the Synofog, the temperature is controlled by the heaters themselves. This means that the frequency of the blower can be adjusted without changing the temperature. The frequency of the blower can be changed as follows:

1. Go to the Technical data tab.

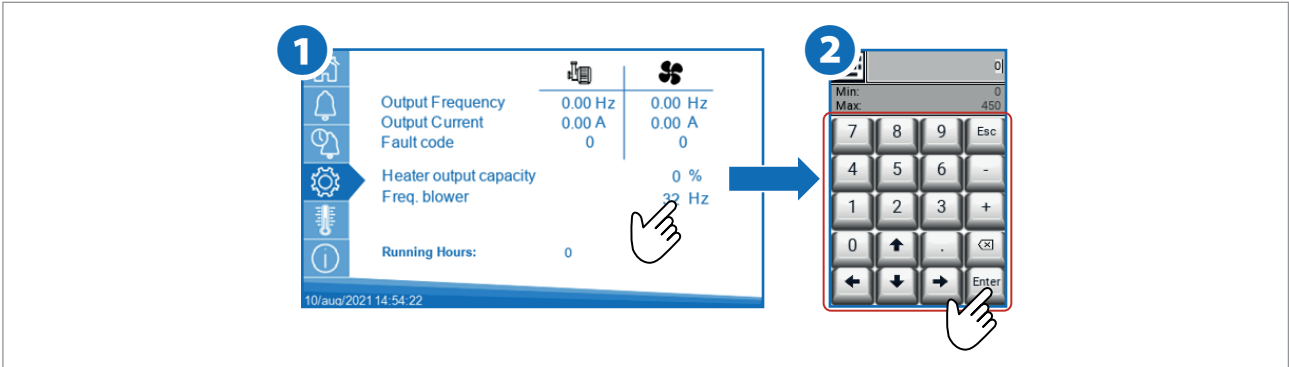

Figure 9 Setting the frequency of the fan

2. Press the value next to Freq. blower.
3. Enter the required blower frequency. Determination of the frequency depends on various factors, in order to achieve an optimum fogging result. Based on user experience and consultation with Veugen Technology, it is possible to determine the ideal frequency for each application. Consult the table below for the possible frequencies of your model.

	Synofog 1HR	Synofog 2HR
Possible frequency values	23 - 50 Hz	32 - 50 Hz

4. Press Enter to confirm the value.



**Caution!**

If, for a period of 3 minutes, the temperature differs from the set Max Temp value by more than 40 °C , a warning is shown on the screen (see figure 10). This warning indicates that the set frequency is too high to meet the set Max Temp. Lower Freq. blower until the message disappears.

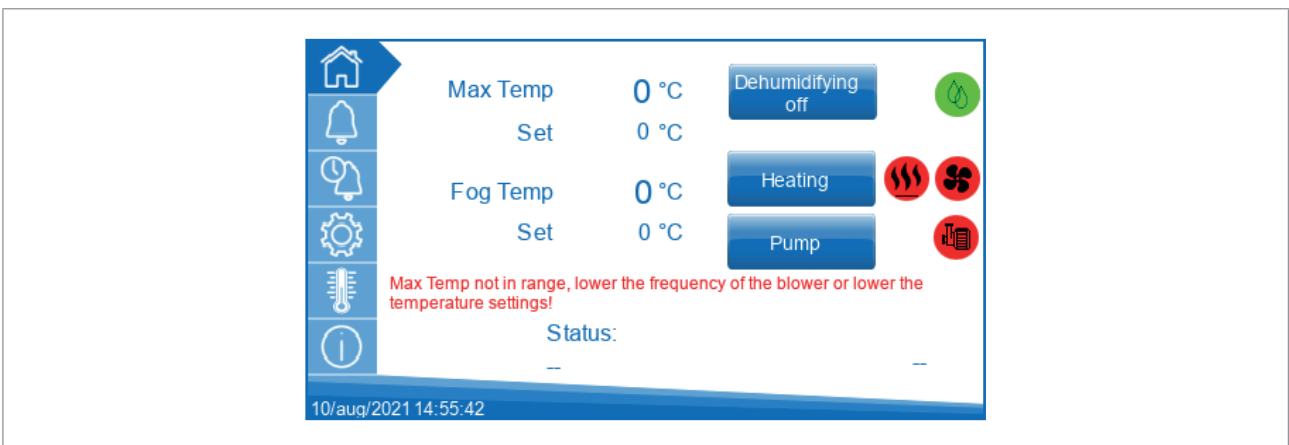

Figure 10 Warning blower frequency too high

# 6. Use

## 6.1. Starting the fogging process

---

The fogging process is started as follows:

1. Press Heating on the display to switch on the heating element.

The machine switches on the dehumidification cycle. The heater and blower switch on for 6 minutes to blow the machine dry and remove condensation.



### Caution!

If necessary, you can shorten the dehumidification cycle by pressing Dehumidifying off. Only do this when you are certain there is no condensation in or on the machine. Condensation increases the risk that the ceramic element breaks.

2. Press Pump to switch on the pump.

The machine heats up and starts fogging automatically when the measured Fog Temp is identical to Fog Set.

## 6.2. During the fogging process

---



### Danger to life!

Do not allow the machine to run without supervision. The operator must always be able to switch off the machine by switching off the main switch.

### TIP

#### Tip!

Under the technical data tab you can read the measured values as the machine runs.

Fogging takes place automatically. Check the following during the fogging process:

- Failures on the display.
- Check that liquid is sucked in.
- Check that there is still sufficient liquid in the liquid container. The end of the suction hose must be fully submerged.
- Check that the fog is distributed in the space properly.
- Check that no unwanted dripping occurs in front of the machine. Increase the Fog Set within the permitted margin, if dripping does occur (see §5.1.2).
- Check the suction filter for clogging.



### Caution!

If the machine is used continuously, it must be cleaned after 100 litres of fogged liquid, in accordance with §7.1.

## 6.3. Switching off the machine

---

The machine is switched off as follows:

1. Press Pump on the display to switch off the pump.
2. Press Heating to switch off the heating element.

The blower continues to work until the temperature in the fogging chamber had dropped below 50 °C.

3. Wait until the blower switches off automatically.
4. Turn the main switch to '0' to switch the machine fully off.
5. Remove the plug from the socket.

## 7. Maintenance



### Warning!

Before you start performing maintenance work:

- Check that the machine is off and that the plug has been disconnected.
- Allow the machine to cool down.

Maintenance is subdivided into two parts:

- Maintenance after use
- Regular maintenance

Maintenance after use may be performed by the user himself. Regular maintenance must be performed by service personnel.

### 7.1. Maintenance after each use

#### TIP

#### Tip!

Do you not understand the instructions in this chapter? Consult the instruction video via the QR code or via <https://www.youtube.com/watch?v=gWmKybkOwoo>



#### 7.1.1. Summary

The following steps must be taken in order to clean the machine:

1. Cleaning the fogging pipe (§7.1.2)
2. Cleaning the fogging chamber (§7.1.3)
3. Rinsing (§7.1.4)
4. Cleaning the fogging pipe (§7.1.2)
5. Cleaning the fogging chamber (§7.1.3)
6. Check if there is still residue in the fogging pipe and/or fogging chamber\*.
7. Replacing the air filter (§7.1.5)

\* If a check shows that the machine is still not clean, repeat the steps starting from step 3.

### 7.1.2. Cleaning the fogging pipe

The fogging pipe is cleaned as follows:

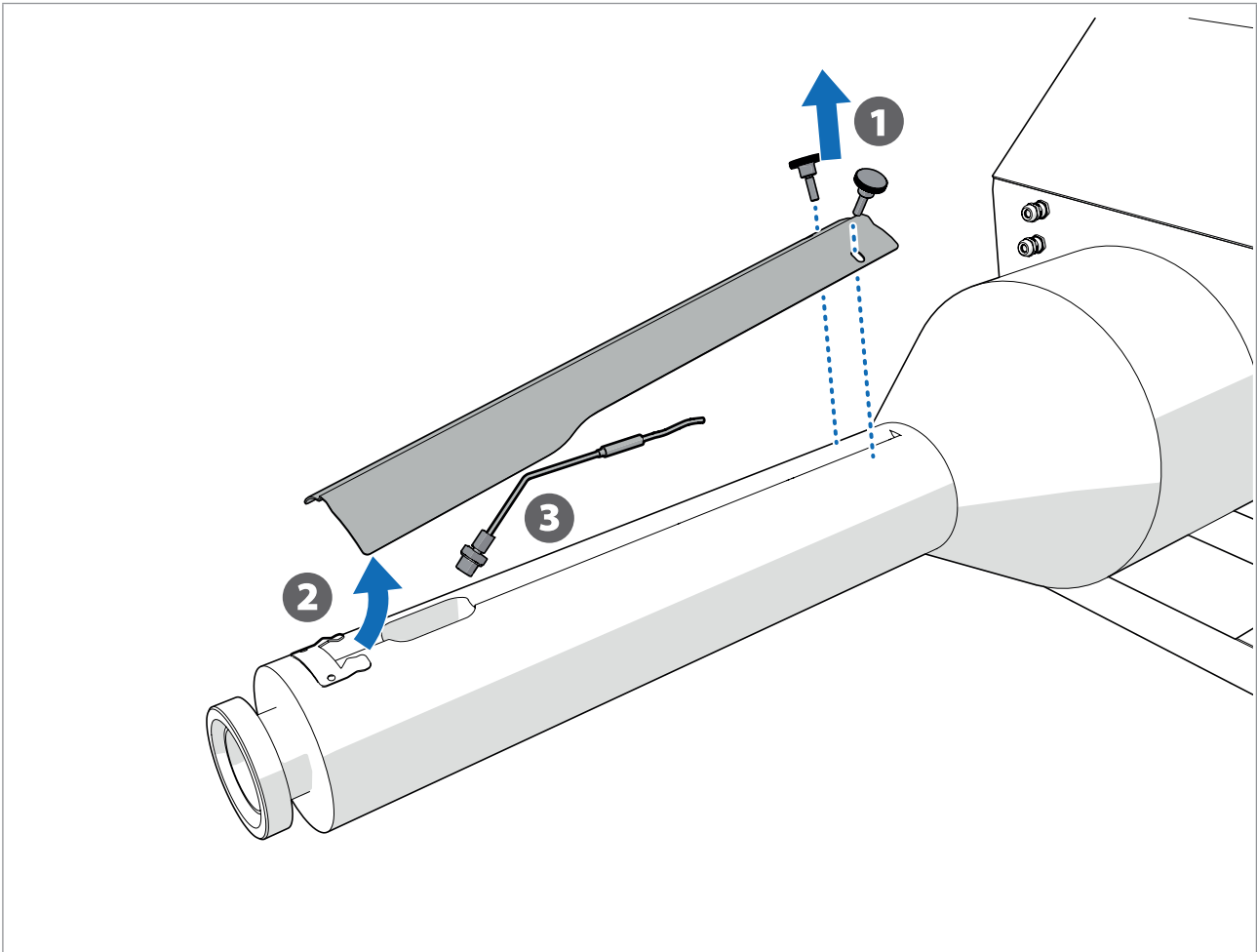

Figure 11 Removing the sensor

1. Remove the cover plate. ①
2. Pull the fogging pipe sensor out of the fogging pipe. ②

#### **TIP** Tip!

- Hang a bucket at the end of the pipe in order to collect the product residue.
- Use the Foam Master (§12.4) to clean the fogging pipe with strong alkaline soap.

3. Remove all the product residue from the inside of the fogging pipe, using the supplied brush.
4. Check that all product residue has been removed.
5. Place the fogging pipe sensor back in the fogging pipe.
6. Place back the cover plate.

### 7.1.3. Cleaning the fogging chamber

The fogging chamber is cleaned as follows:

1. Disconnect the liquid pipe (see §5.1.1).

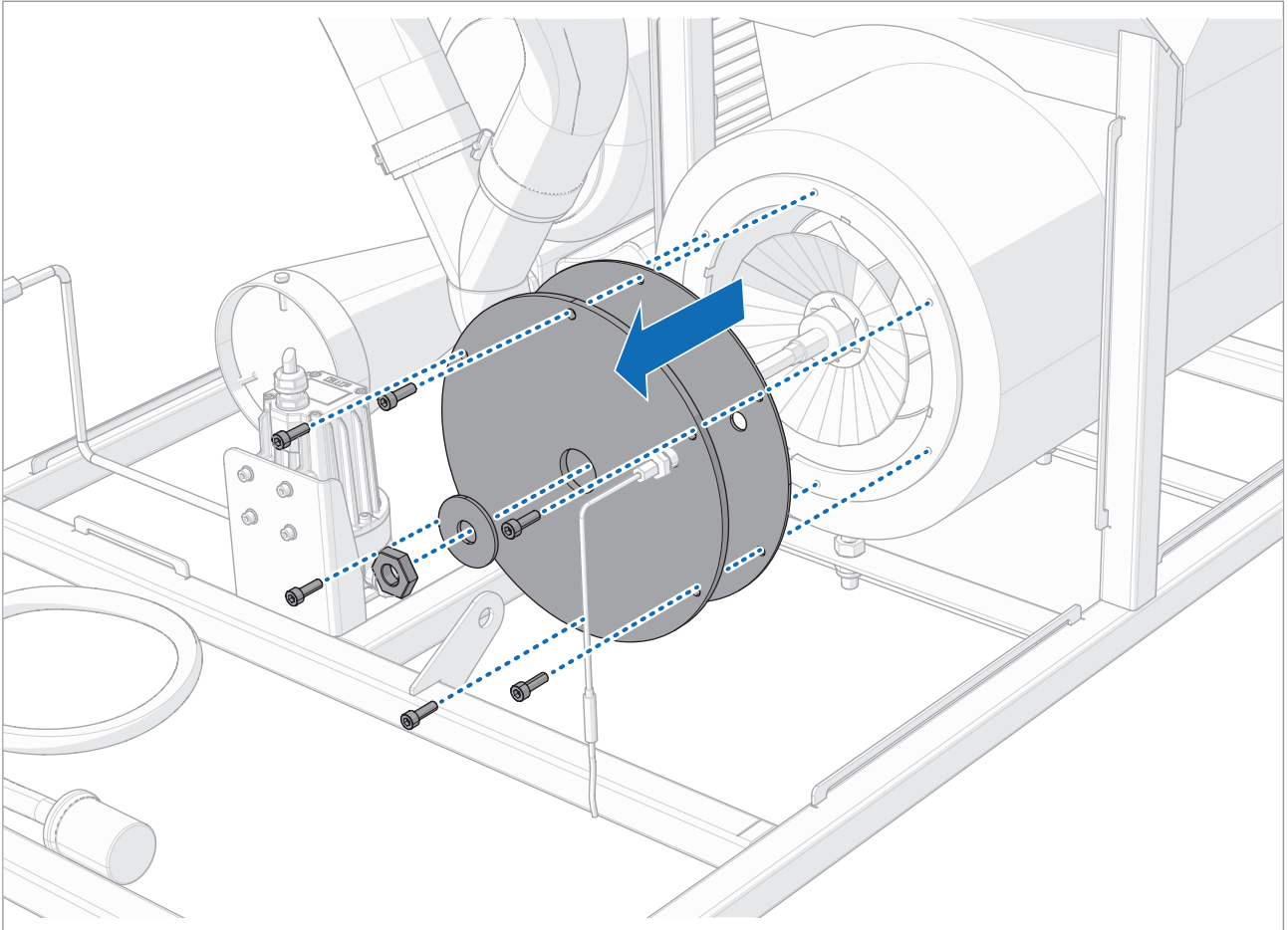

Figure 12 Opening the back plate with heat seal

2. Remove the back plate with heat seal from the machine.
3. Remove the nozzle head from the misting chamber
4. Remove loose product residue in the fogging chamber, using a sweeper or a vacuum cleaner.
5. Remove all other product residue from the inside of the fogging chamber, using the supplied brush.
6. Check that all product residue has been removed.
7. Place the nozzle head back into the nebulisation chamber.
8. Place the back plate with heat seal back on the machine.
9. Connect the liquid pipe again (see §5.1.1).

#### 7.1.4. Rinsing

The machine is rinsed as follows:

1. Tilt the machine in such a way that the fogging pipe tilts downward slightly.

#### **TIP** Tip!

- For rinsing the machine, use a strong alkaline soap. We recommend Cleanbest 1400 (50% water, 50% Cleanbest 1400).
- To make rinsing easier, you can also use the Foam Master (see §12.4).

2. Suspend the suction hose in the soap mixture.
3. Set the machine with the following temperature values:
  - Max Temp: 180 °C
  - Fog Temp: 80 °C
4. Press Heating to switch on the heating element.
5. Press Pump to switch on the pump

After a few minutes, the soap mixture will come out of the fogging pipe.

6. Wait until the stream of liquid from the fogging pipe has become clear.
7. Set the Max Temp to 100 °C.
8. Press Pump to switch off the pump.
9. Wait 3 minutes, in order to blow the machine dry.
10. Press Heating to switch off the heaters
11. Wait until the machine has cooled down.
12. Switch off the machine.

#### 7.1.5. Replacing the air filter

The air filter is replaced as follows:

1. Remove the air filter from the air filter holder.
2. Place a new air filter in the air filter holder (§7.1.5).

#### **TIP** Tip!

New air filters can be ordered from your supplier.

## 7.2. Regular maintenance

---

We recommend to have the machine maintained and tested according to local legislation once per year.

## 7.3. Repairs

---

During the warranty period, repairs may only be performed by your supplier. Repairs performed upon your own initiative will invalidate the warranty for parts that have been tampered with.

All replacement parts should at least comply with the specifications of the original parts.

All parts can be ordered from your supplier. See §12 for an overview of replacement parts.



# 8. Troubleshooting

The machine can indicate a failure in two ways:

- Alarm via the screen
- Signal via the LED indicators on electrical component PG1

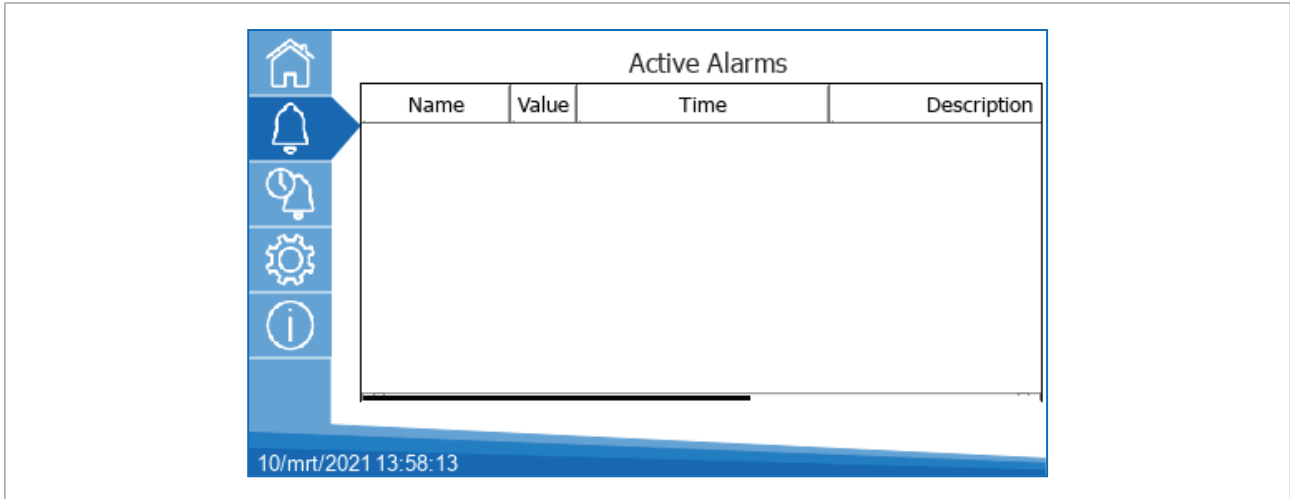







Figure 13 Active alarms

**TIP** **Tip!**  
The alarm history can be viewed on the alarm history tab.

Contact your supplier if you are unable to resolve the problem with the instructions in this chapter.

## 8.1. Alarm via the screen

Consult the table below for information about possible alarms.

Alarm	Possible cause	Possible solution
 <p>Fog Temp too high Check system</p>	For 3 minutes, Fog Temp is 40 °C higher than the set value.	<ul style="list-style-type: none"> <li>- Check the tank contents.</li> <li>- Does the liquid pump suck in liquid?</li> <li>- Does the pump provide sufficient pressure?</li> </ul>
 <p>High Temperature Alarm Service Required!</p>	The fogging pipe sensor measures a temperature above 500 °C. It is very likely that a fire has occurred in the fogging pipe.	<ul style="list-style-type: none"> <li>- Switch off the machine in accordance with §6.3.</li> <li>- Check the suction filter for contamination.</li> <li>- Clean the machine in accordance with §7.1.</li> </ul>
 <p>Heater temp too High</p>	The heater measures a temperature above 500 °C.	
 <p>Temperature difference heaters Service required!</p>	The temperature difference between the heating elements is too great. A heating element is defective.*	<ul style="list-style-type: none"> <li>- Check the function of all heating elements.</li> <li>- Replace defective heating elements (see §11).</li> </ul>
 <p>Temperature sensor defect Service required!</p>	A sensor is defective.	<ul style="list-style-type: none"> <li>- Check the function of all sensors.</li> <li>- Replace defective sensors (see §11).</li> </ul>
	There is a failure in the power supply.	<ul style="list-style-type: none"> <li>- Consult §8.2.</li> </ul>

\* This alarm can only occur at the Synofog 2H.

## 8.2. Alarm via LED indicators

A failure in the power supply can be investigated via the LED indicators. The LED indicators are located in the cabinet on electrical component PG1 (see figure 14).

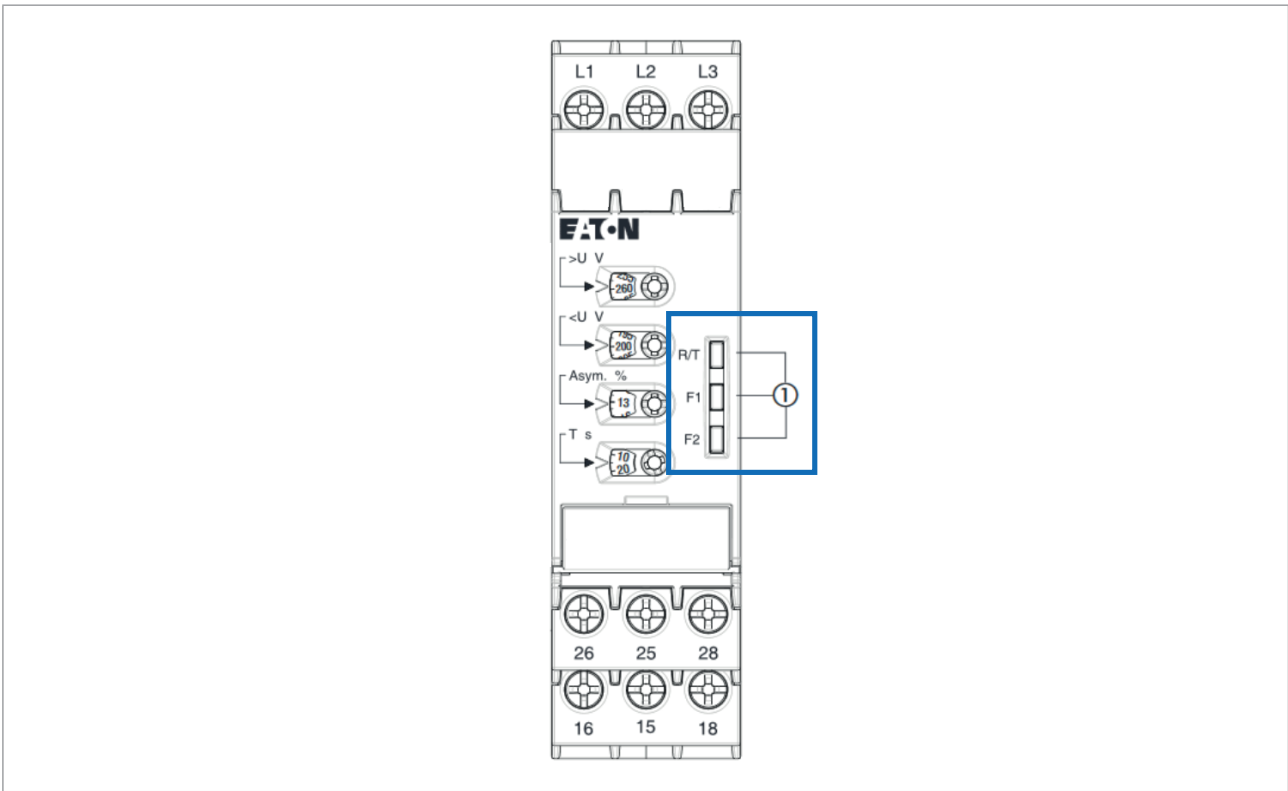

Figure 14 LED indicators on electrical component PG1.

Consult the table below for information about possible alarms.

Indicator	Cause	Possible solution
LED yellow: R/T on	Supply voltage	Normal operation, no action required
LED yellow: R/T Flashes	Delay time running	Normal operation, no action required
LED red: F1 on	Overvoltage	Voltage higher than 430 V, consult an electrical engineer
LED red: F2 on	Undervoltage	Voltage lower than 360 V, consult an electrical engineer
LED red: F1 & F2 on	Imbalance between phases	Voltage difference between the phases, consult an electrical engineer
LED red: F1 on, F2 flashes	Phase failure	No voltage on one of the phases, consult an electrical engineer
LED red: F1 & F2 flashes (F1 & F2 alternating)	Phase sequence error	Incorrect phase sequence, ask the manufacturer for information

## 9. Disposal

In case of a defective product, first contact your supplier. It may be possible to repair your machine. If the machine must be disposed of, dispose of the machine in accordance with locally applicable regulations.

Only materials were used in the machine which, at the time of construction, were not known to pose any special risks during disassembly.

The fogging liquids, air filter and contaminated hoses must be disposed of as chemical waste.

## 10. Contact

---

<b>Manufacturer</b>	Veugen Technology B.V.
<b>Address</b>	Platinastraat 9 6031 TW Nederweert The Netherlands
<b>Telephone</b>	+31 (0)495 460 188
<b>E-mail</b>	info@veugentech.com

---

## 11. Replacement parts

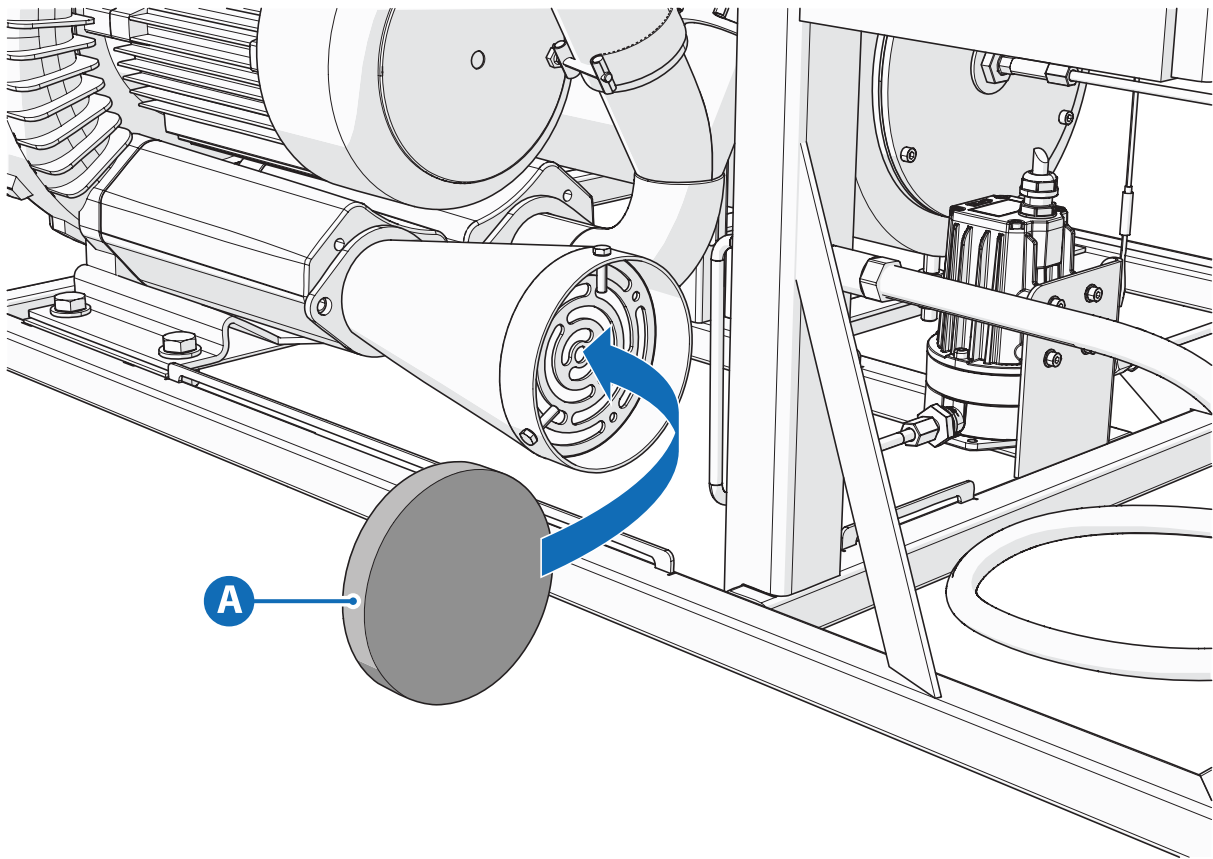

	Item number	Description	Quantity 1H	Quantity 2H
A	030430	Filter Turbofogger F290	1 (back up: 25)	1 (back up: 25)

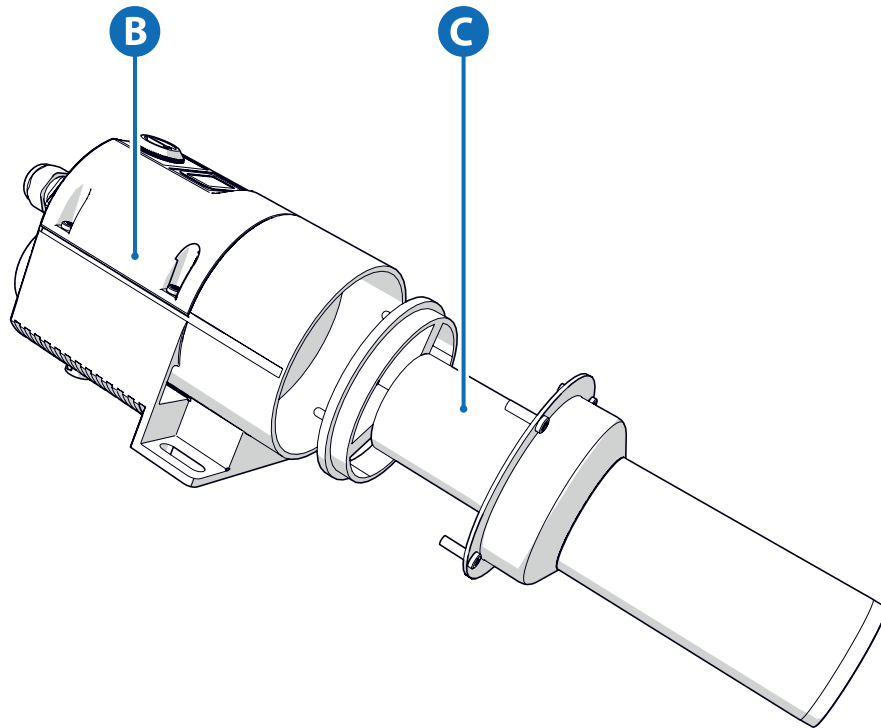

	Item number	Description	Quantity 1H	Quantity 2H
<b>B (H versions)</b>	291053	Air heater 9kw	1	2
<b>B (HR versions)</b>	291056	Air heater 9kw	1	2
<b>C</b>	291063	Heating element heater	1	2

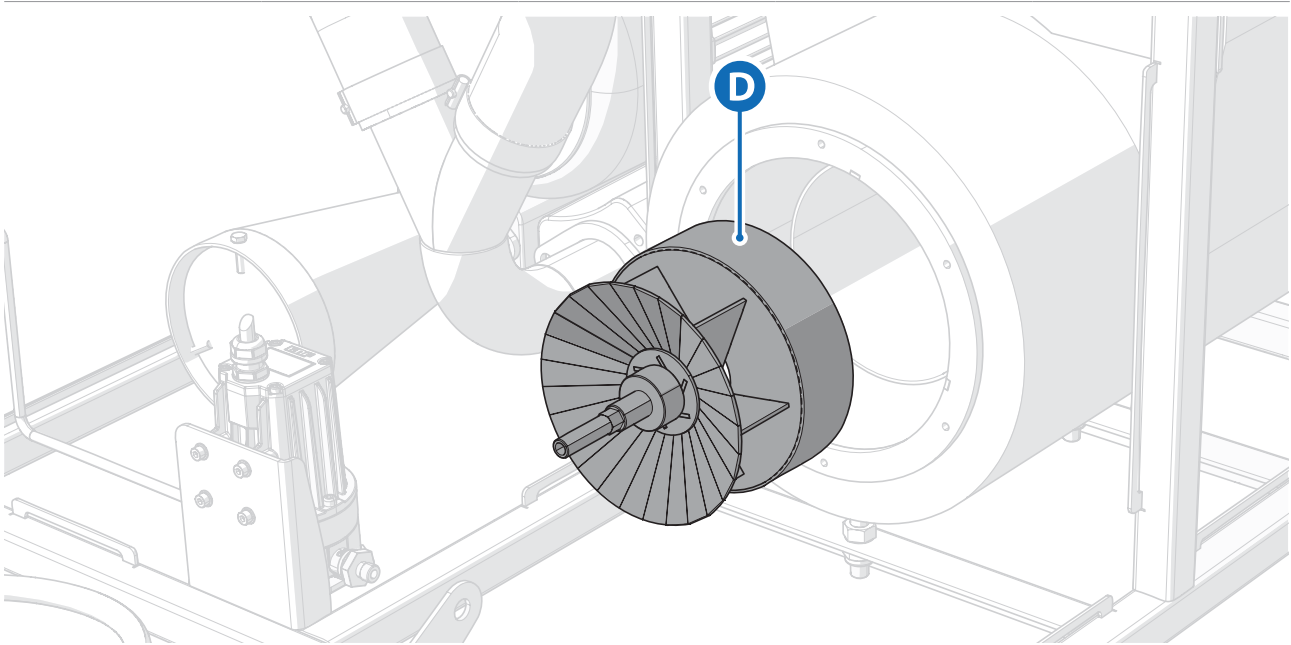

	Item number	Description	Quantity 1H	Quantity 2H
<b>D</b>	291662	Impeller nozzle RVS SF1H	1	
<b>D</b>	292662	Impeller nozzle RVS 2HSF		1
<b>D</b>	292692	Impeller nozzle RVS 2HSF (<181111)		

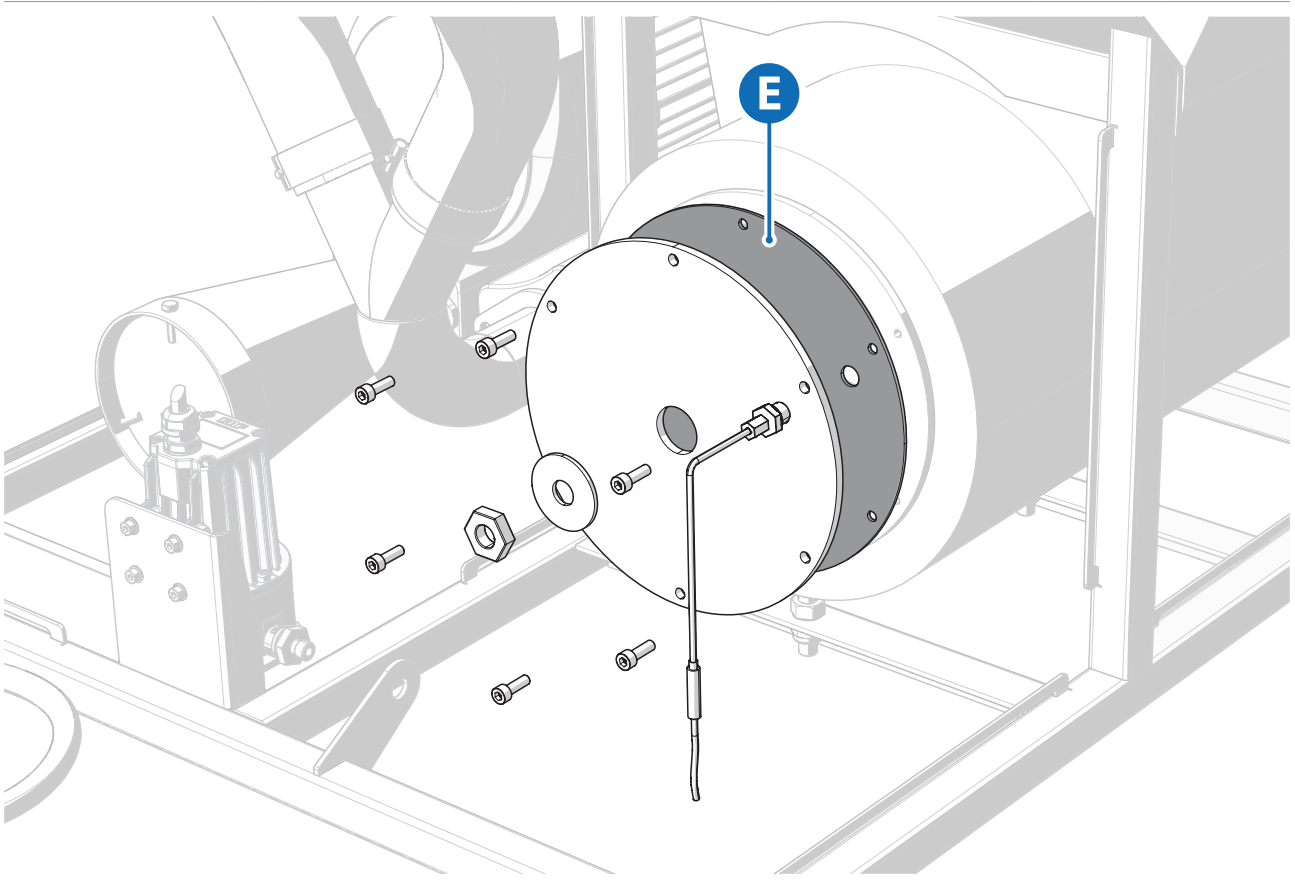

	Item number	Serial number	Description	Quantity 1H	Quantity 2H
E	291083		Heat seal nozzle SF1H ø100 (Impeller head)	1	
E	291085		Heat seal nozzle SF1H ø124 (Impeller head)	1	
E	292081	to 181110	Heat seal nozzle SF2H ø136 (Impeller head)		
E	292083	190910 to 200725	Heat seal nozzle SF2H ø166.3 (Impeller head)		1
E	292085	From 200706	Heat seal nozzle SF2H ø198.3 (Impeller head)		1



### Impeller nozzle sets

	Item number	Description	Quantity 1H	Quantity 2H
D & E	292667	Impeller nozzle set Synofog 2H 50mm (>190910)		
D & E	292662	Impeller nozzle set Synofog 2H 50mm (>200706)		
D & E	292669	Impeller nozzle set Synofog 2H 40mm (>181111)		

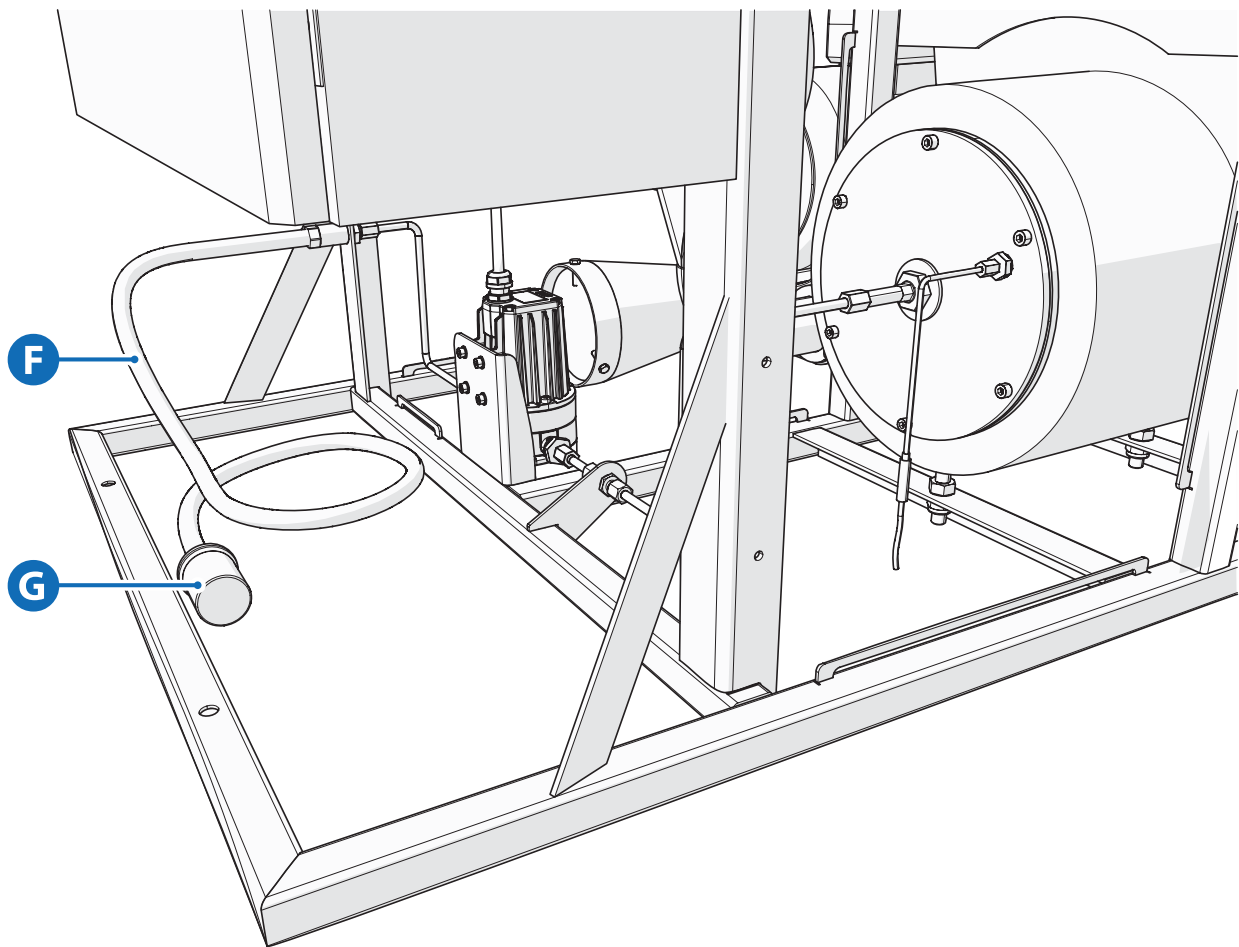

	Item number	Description	Quantity 1H	Quantity 2H
F	010047	Silicone hose (red)	1x 1.5 m	1x 1.5 m
F	010041	Viton hose (black)	1x 1.5 m	1x 1.5 m
G	291635	Suction sieve	1	1

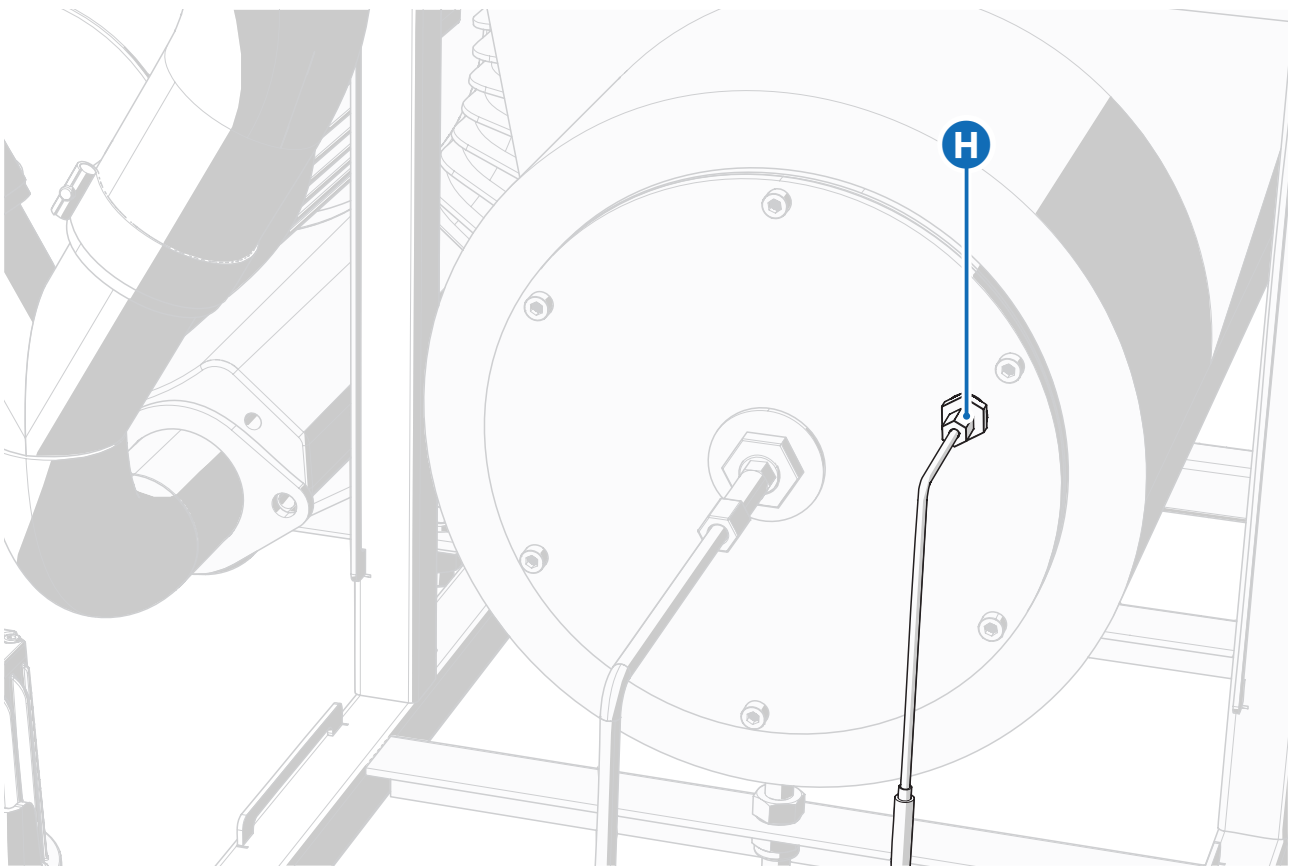
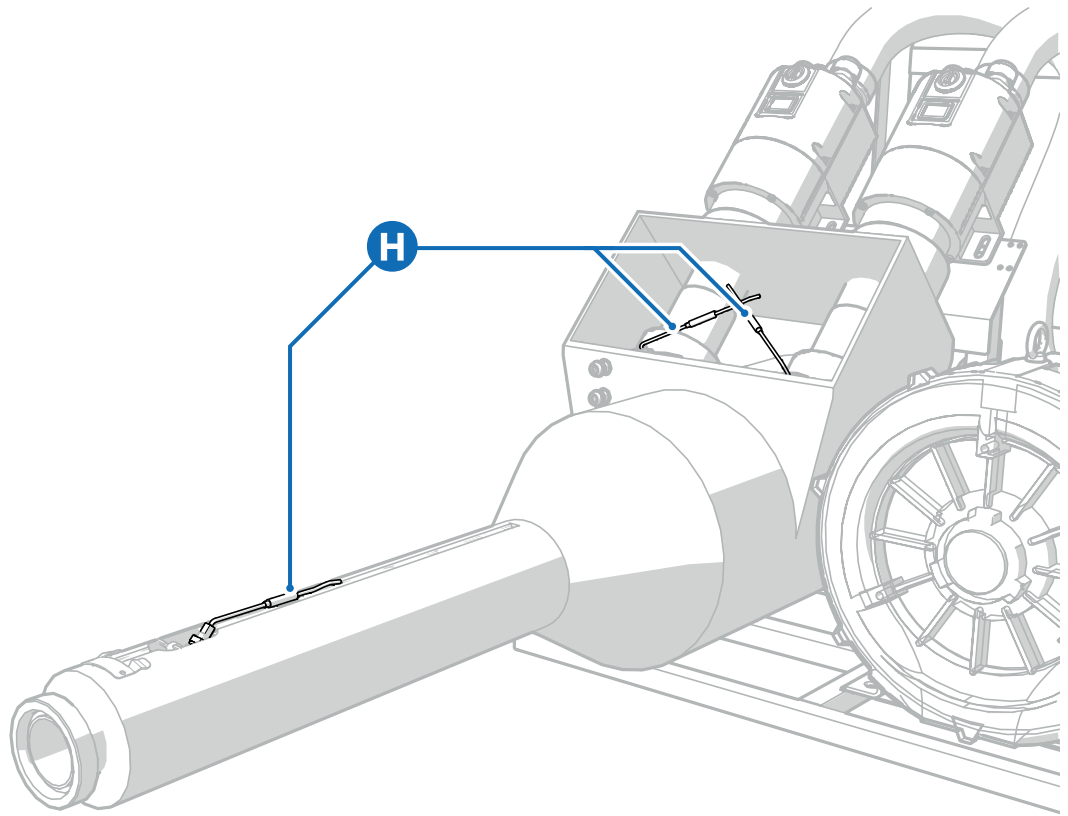

	Item number	Description	Quantity 1H	Quantity 2H
H	105499	Thermocouple round 3x200 2.5 mtr cable	3	4

## 12. Accessories

### 12.1. Extension pieces

Not every location allows aiming the machine in such a way that an optimum fog distribution is achieved. These extension pieces were developed to provide more flexibility. Any shape of extension piece is possible. Please contact your supplier for a customised solution.

Item number	Name	Figure
291510	Extension piece SF1H Ø30 straight 600 mm	
292610	Extension piece SF2H Ø50 straight 600 mm	
291511	Extension piece SF1H Ø30 straight 400 mm + 90° bend	
292611	Extension piece SF2H Ø50 straight 400 mm + 90° bend	
291501	Extension piece SF1H bent centre-to-centre: 200 mm	
292600	Extension piece SF2H bent Ø50	
291615	Extension piece SF1H Ø30 flexible hose 1 m	
292615	Extension piece SF2H Ø50 flexible hose 1 m	
291616	Extension piece SF1H Ø30 flexible hose 2 m	
292616	Extension piece SF2H Ø50 flexible hose 2 m	
291520	Extension piece SF1H bounce plate	
292620	Extension piece SF2H bounce plate	

## 12.2. Wi-Fi



WiFi hotspot module

With the WiFi accessory, your Synofog is equipped with a WiFi hotspot module. This means that your smartphone can be connected to the Synofog in order to operate the display from your smartphone. The radius of the hotspot is maximum 100 metres (free space).



### Danger to life!

Do not allow the machine to run without supervision. The operator must always be able to switch off the machine by switching off the main switch.



Wi-Fi sticker

On the side of the control cabinet, above the serial number sticker, you will find the sticker with the WiFi connection data. Making a connection with the WiFi network is done as follows:

1. Open the WiFi settings of your smartphone or tablet.
2. From the list, select the Wi-Fi network with the name stated at SSID on the Wi-Fi sticker.
3. Enter the password stated at Password (above) on the Wi-Fi sticker.

The smartphone or tablet is now connected to the Wi-Fi network. Taking over operation is done as follows:

1. Open an internet browser on your smartphone or tablet.
2. Enter address 10.0.0.180 in the address bar. A log on screen appears.
3. Log on with the data at User and Password (below) on the Wi-Fi sticker.

Now you can operate the Synofog from your smartphone or tablet.

### 12.3. 4G







4G module

With the 4G accessory, your Synofog is equipped with a 4G antenna and a SIM card. This allows us to provide remote support.

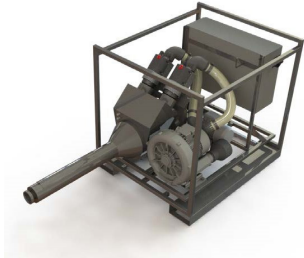
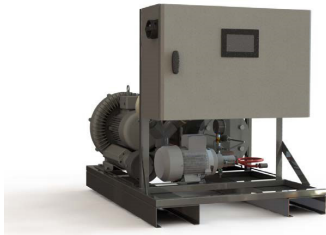
After the first year, internet costs will apply. Ask your supplier for the subscription fees.

### 12.4. Other accessories

Item number	Name	Figure
291600	Rain/heat cover SF	
292599	Protection frame SF	
205109.05	Forklift sleeves 930mm	

-	WiFi SF1H + SF2H	
291667	Impeller head	
-	Powerlimit	

# 13. Guarantee

Unless otherwise agreed in writing, the following guarantee provisions apply.

- The manufacturer provides a guarantee to the first user for a period of 12 months after delivery.
- Defects must be reported to the manufacturer before the end of the guarantee period.
- The guarantee is applicable to defects that:
  - occur during normal use of the product/installation;
  - originate due to improper construction or materials;
  - originate due to faulty workmanship by the manufacturer.
- The guarantee does not apply in case of defects that occur due to:
  - normal wear and tear;
  - incompetent or inappropriate use;
  - use of other consumables than specified.
- In the event of defects, the manufacturer will:
  - replacing parts, the manufacturer becomes the owner of the replaced parts;
  - remedy the defects;
  - choose a substitute solution if repair is not reasonably possible.
- The customer must give the manufacturer the opportunity to remedy any defects.
- For built-in parts from third parties, the guarantee provisions of the supplier concerned shall apply. The guarantee period can also differ from the period stipulated above.
- The manufacturer reserves the right to modify its machines/installations without prior warning.

We draw attention to the following liability restrictions:

The manufacturer cannot be held liable for unsafe situations, accidents or damage as a result of disregarding warnings or conditions as shown on the product/installation or mentioned in this documentation, for example:

- incompetent or incorrect use or maintenance;
- use for other applications or in different conditions to those mentioned in this documentation;
- use of parts other than those specified;
- repairs without the permission of the manufacturer;
- changes to the product/installation, including:
  - changes to the control system;
  - welding, mechanical processes;
  - extensions to the product/installation or the control system.

The manufacturer also cannot be held liable:

- If the customer has not fully complied with all his obligations with respect to the manufacturer (financial or otherwise);
- for consequential damage due to failures or defects in the product/installation (for example damage to products to be processed, operational stoppages, delays, etc.);
- for damage resulting from incorrect supply voltages outside 360-430V;
- for damage to the ceramic components within the heating element;
- For damage to the gear pump due to contaminated liquids.
- For products not supplied, or modifications by the user.
- For damage resulting from unsound electrical installation / supply voltage / extension cables. These must meet local regulations.

# 14. EC declaration of conformity

**We** Veugen Technology B.V.  
Platinastraat 9  
6031 TW Nederweert  
The Netherlands  
Tel.: +31 (0)495 460 188

declare entirely under our own responsibility:

1) We are the producer of the machine:

**Synofog** Make: Synofog  
Type:  
Serial No.: All serial numbers of  
this type

to which this declaration relates.

2) The machine is designed and constructed in compliance with the requirements of Machinery Directive 2006/42/EC

3) The machine meets the requirements of the following other EC directives:

2014/30/EU EMC Directive  
2009/127/EC  
EN ISO 13732

4) The machine is designed and constructed according to the following (European) standards or normative documents:

NEN-EN-ISO 12100: 2010 Safety of machinery - general principles for design - Risk assessment and risk reduction.

Signed at Nederweert

Date: 3-2-2017

Signed by: Jos Veugen

Function: Director











