

HALOFOG 400

PATENT PENDING - Automatic Truck Disinfection

Complete disinfection with the push of a button

The Halofog 400, also called Truck Disinfection Unit (TDU), is an integrated fogging system for disinfecting trailers with only a push of a button. A very fine and dry fog can be injected into the trailer with a nozzle operating on compressed air. This dry fog ensures there are no wet spots inside the trailer and ensures high penetration in nooks and crevices. Not only the trailer, but also everything inside the trailer like carts, crates and boxes will be disinfected. Suitable for all trailers where extra hygiene is required.

Optionally, the Halofog 400 can be used for fogging for humidification. With a humidistat the humidity can be regulated. Fog is injected when the humidity drops below a set level. **Other options include:** complete inside and outside disinfection, including wheel disinfection.

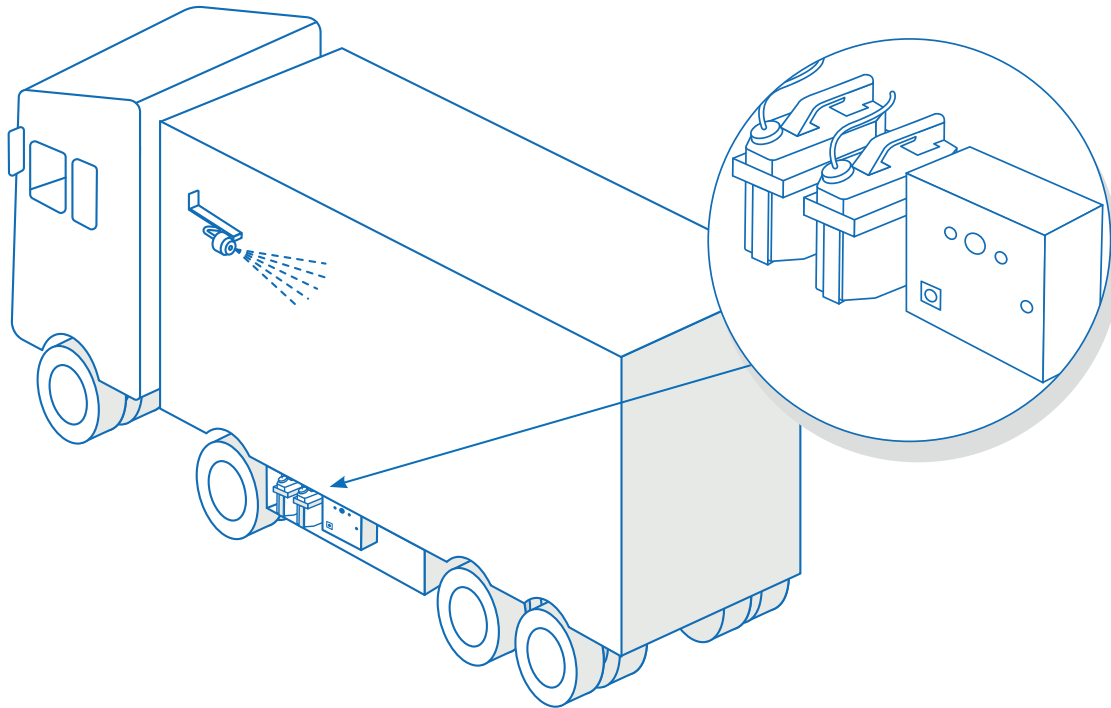

Depending on the options on your fogger, your product may look different from the image.

Version February 2025



Photocredit: Heering

FOGGING & HYGIENE

HALOFOG 400

PATENT PENDING - Automatic Truck Desinfection

Specifications

- **Completely automatic desinfection of the trailer**
- Starting desinfection can be done from inside the cabin
- Can be used with different types of disinfectants like Quats, Aldehydes, Peroxide, and Formaldehyde
- The system can operate till -20° Celcius when using an additive
- **Complete stainless steel** nozzles and valves
- For all trailers with extra hygiene requirements



Capacity

Desinfects 40 m³
in 10 minutes.



Tank size

1 Tank
Up to 30 treatments.



Air throw

n/a.



Power

n/a.



Droplet size

5 - 10 µm.



Mobility

Fixed installation.

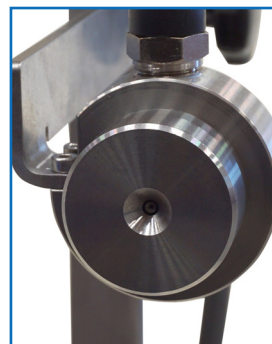

Version February 2025
Depending on the options on your fogger, your product may look different from the image.